

# Hand pallet truck 2.0 ton

**BT lifter**

*L-series*

LHM200ST



# Hand pallet truck

Truck specifications					LHM200ST
Identification	1.1	Manufacturer			BT
	1.2	Manufacturer's type designation			LHM200ST
	1.4	Operator type			Hand
	1.5	Load capacity/rated load	Q(t)	kg	2000
	1.6	Load centre distance	c	mm	600
	1.8	Load distance, centre of drive axle to fork	x	mm	940 <sup>1)</sup>
	1.9	Wheelbase	y	mm	1170 <sup>1)</sup>
Weight	2.1	Service weight		kg	70
	2.2	Axle load, with load, drive/castor/fork wheel		kg	375/805
	2.3	Axle load, without load, drive/castor/fork wheel		kg	20/10
Wheels	3.1	Steer/fork wheels: Nylon (N), Polyurethane (P), Rubber (R),			N, P, R/N, P
	3.2	Wheel size, front			175x60
	3.3	Wheel size, rear			85x100 / 85x75 <sup>2)</sup>
	3.5	Wheels, number front/rear (x=driven wheels)			2/2 or 2/4 <sup>2)</sup>
	3.6	Track width, front	b <sub>10</sub>	mm	132
	3.7	Track width, rear	b <sub>11</sub>	mm	364
	Dimensions	4.4	Lift	h <sub>3</sub>	mm
		Lift height	h <sub>23</sub>	mm	200
4.9		Height of tiller in drive position, min./max.	h <sub>14</sub>	mm	1220
4.15		Height, lowered	h <sub>13</sub>	mm	85
4.19		Overall length	l <sub>1</sub>	mm	1520
4.20		Length to face of forks	l <sub>2</sub>	mm	370
4.21		Overall width	b <sub>1</sub> /b <sub>2</sub>	mm	520/695 <sup>3)</sup>
4.22		Fork dimensions	s/e/l	mm	45/156/1150 <sup>4)</sup>
4.25		Width over forks	b <sub>5</sub>	mm	520/685 <sup>3)</sup>
4.32		Ground clearance, centre of wheelbase	m <sub>2</sub>	mm	40
4.33		Aisle width for pallets 1000 x 1200 crossways	A <sub>st</sub>	mm	1525 <sup>1)</sup>
4.34		Aisle width for pallets 800 x 1200 lengthways	A <sub>st</sub>	mm	1725 <sup>1)</sup>
4.35		Turning radius	W <sub>a</sub>	mm	1370 <sup>1)</sup>

1) Distance with forks raised

2) Single wheel / Boggie wheel

3) Other widths available on request

4) Other fork length available: 800/910/1000/1070/1220

All data are based on table configuration. Other configurations may give other values.

Truck performance and dimensions are nominal and subject to tolerances.

Specifications are subject to change without notice.

# Dimensional drawings

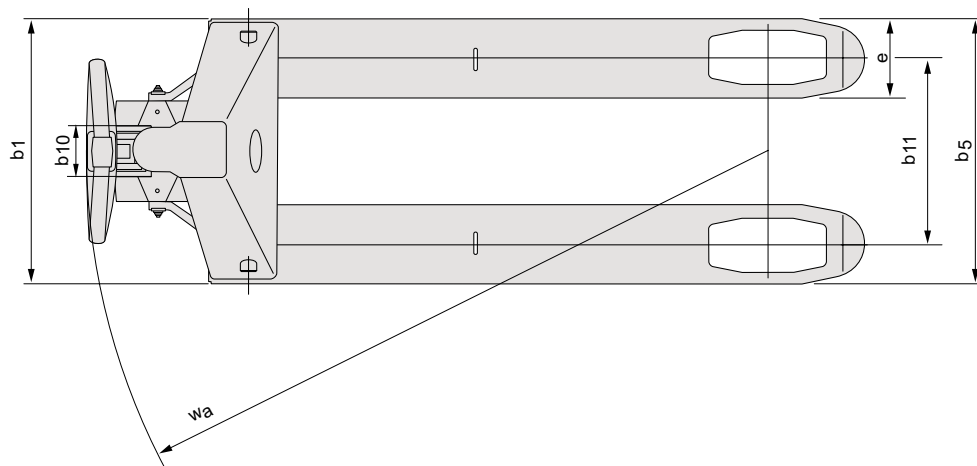
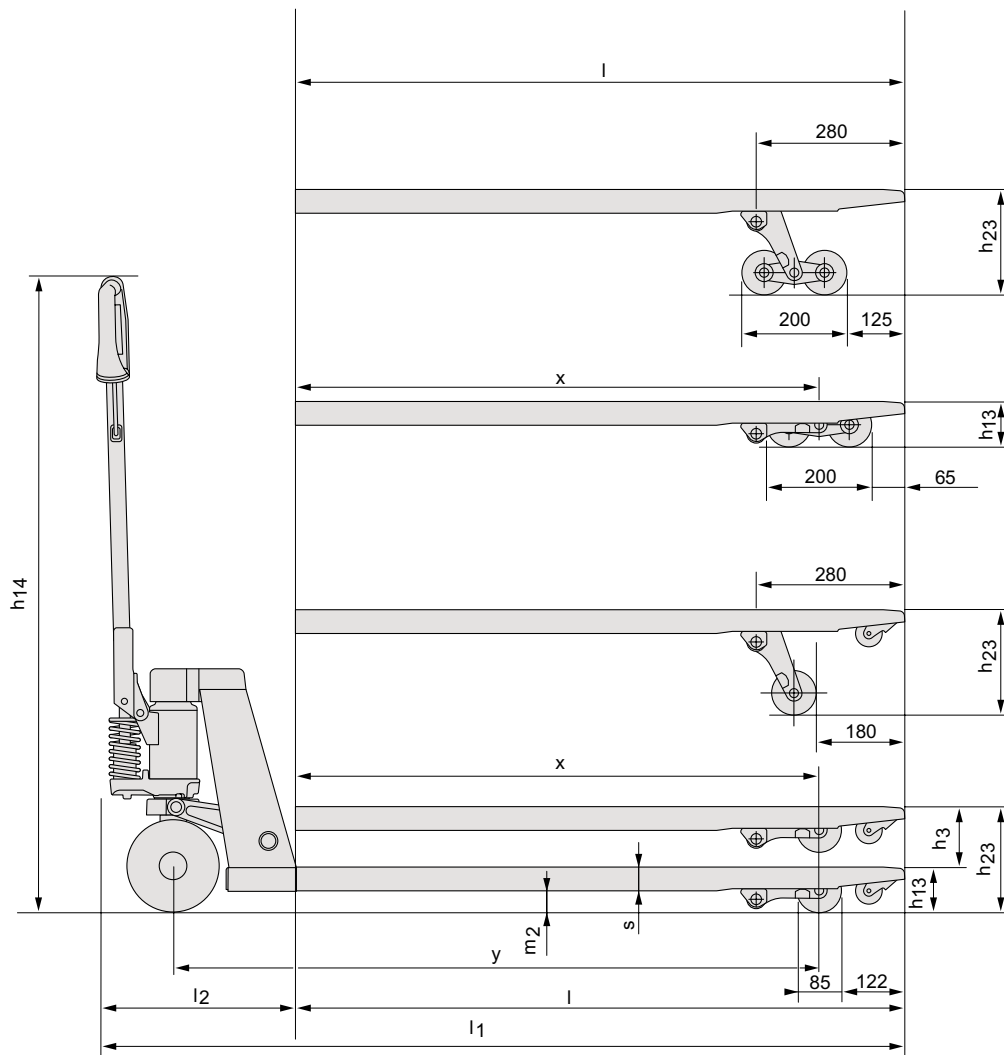

---

## Truck features:

- All components in stainless steel or other non-corroding materials improves reliability and long life.
- All surfaces are glass blasted – giving a smooth surface and ensuring easy cleaning.
- Welded tow bar attachment – provides high reliability.
- Greasable bushings ensure a long service life.
- Also available in low fork height (U-model) with minimum height 75 mm.
- This product has been environmentally declared.



TP-Technical Publications, Sweden — 745100-040, version 1, 0908